

# Product Specification

<b>Product:</b>	<b>Particulate Matter Sensor</b>
<b>Product model:</b>	PMSA003-A
<b>Specification No.:</b>	PTQ3033-2017
<b>Version:</b>	V1.0

Writer	Verifier	Standardization	Approver
Zhao Zhendong	Zheng Haoxin	Lu Lili	Zhou Yong
2019-2-20	2019-2-20	2019-2-20	2019-2-20

ADD: 6/f, Building 9, Yuxi Road No. 9, Houshayu, Shunyi district, Beijing, P. R. China

TEL: 010-64731933

FAX: 010-64737980

URL: [www.plantower.com](http://www.plantower.com)

Email: [info@plantower.com](mailto:info@plantower.com)

<b>PLANTOWER</b> 攀藤科技	<b>PMSA003-A Datasheet</b>	DOCUMENT No	PTQ3033-2017
		Version	V1.0
		Date	2019-2-20

## Catalogue

Log Page .....	2
1. Main characteristics .....	3
2. Overview .....	3
3. Working principle .....	4
4. Technical Index .....	4
5. Output result .....	6
6. Pin Definition .....	6
7. Typical Circuit .....	7
8. Circuit Attentions .....	7
9. Typical Output Characteristic .....	8
10. Endurance Characteristics .....	10
11. Part Number Definition .....	13
12. Physical Size .....	14
13. Installation Attentions .....	15
14. Other Attentions .....	15
15. Appendix A: Transport Protocol Active Mode .....	16
16. Appendix B: Transport Protocol Passive Mode .....	17

DOCUMENT No	PTQ3033-2017
Version	V1.0
Date	2019-2-20

**Log Page**

Version	Note	Date	Writer
V1.0	Newly-built	2019.2.20	Lu Lili

<b>PLANTOWER</b> 攀藤科技	<b>PMSA003-A Datasheet</b>	DOCUMENT No	PTQ3033-2017
		Version	V1.0
		Date	2019-2-20

## 1. Main characteristics

- ◆ Zero false alarm rate
- ◆ Real-time response
- ◆ Correct data
- ◆ Minimum distinguishable particle diameter :0.3 micrometer
- ◆ High anti-interference performance because of the patent structure of six sides shielding
- ◆ Optional direction of air inlet and outlet in order to adapt the different design
- ◆ Smallest

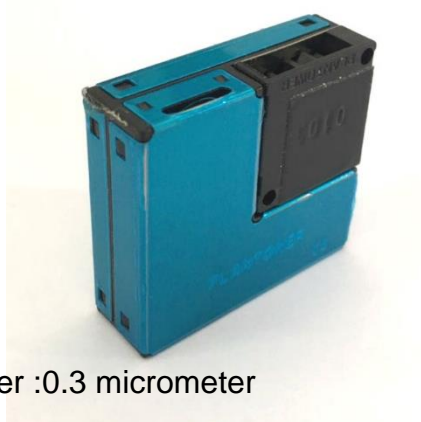

## 2. Overview

PMSA003-A is a kind of digital and universal particle concentration sensor, which can be used to obtain the number of suspended particles in the air, i.e. the concentration of particles, and output them in the form of digital interface. This sensor can be inserted into variable instruments related to the concentration of suspended particles in the air or other environmental improvement equipments to provide correct concentration data in time.

<b>PLANTOWER</b> 攀藤科技	<b>PMSA003-A Datasheet</b>	DOCUMENT No	PTQ3033-2017
		Version	V1.0
		Date	2019-2-20

### 3. Working principle

Laser scattering principle is used for such sensor, i.e. produce scattering by using laser to radiate suspending particles in the air, then collect scattering light in a certain degree, and finally obtain the curve of scattering light change with time. In the end, equivalent particle diameter and the number of particles with different diameter per unit volume can be calculated by microprocessor based on MIE theory. Please find the functional diagram of each part of sensor from Figure 1 as follows.

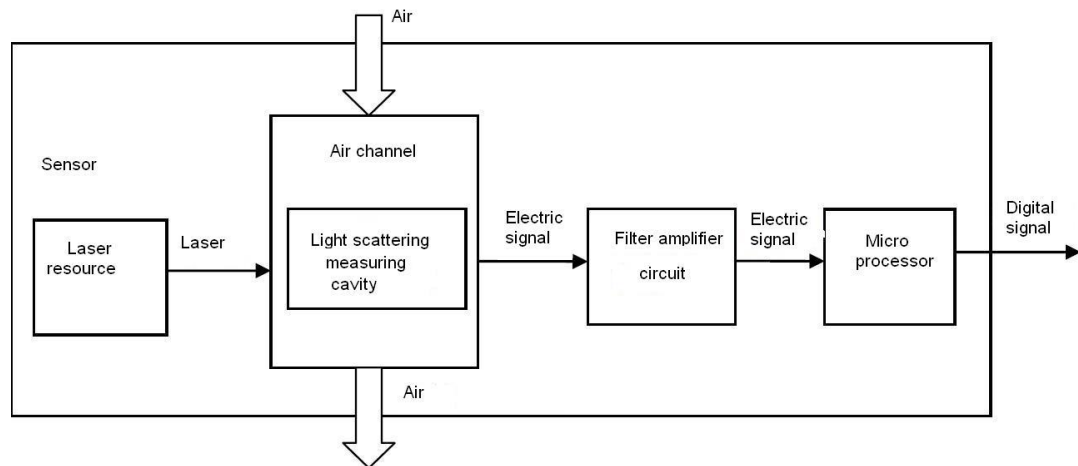

Figure 1 Functional block diagram of sensor

### 4. Technical Index

Parameter	Index	unit
Particle Range of measurement	0.3~1.0; 1.0~2.5; 2.5~10	Micrometer ( $\mu\text{m}$ )
Particle Counting Efficiency	50% $@0.3\mu\text{m}$ 98% $@\geq 0.5\mu\text{m}$	

<b>PLANTOWER</b> 攀藤科技	<b>PMSA003-A Datasheet</b>	DOCUMENT No	PTQ3033-2017
		Version	V1.0
		Date	2019-2-20

Particle Effective Range (PM2.5 standard)	0~500	$\mu\text{g}/\text{m}^3$
Particle Maximum Range (PM2.5 standard) *	$\geq 1000$	$\mu\text{g}/\text{m}^3$
Particle Resolution	1	$\mu\text{g}/\text{m}^3$
Particle Maximum Consistency Error (PM2.5 standard data)*	$\pm 10\% @ 100 \sim 500 \mu\text{g}/\text{m}^3$ $\pm 10 \mu\text{g}/\text{m}^3 @ 0 \sim 100 \mu\text{g}/\text{m}^3$	
Particle Maximum Consistency Error (PM1.0 standard data)	$\pm 15\% @ 100 \sim 500 \mu\text{g}/\text{m}^3$ $\pm 15 \mu\text{g}/\text{m}^3 @ 0 \sim 100 \mu\text{g}/\text{m}^3$	
Particle Maximum Consistency Error (PM10 standard data)	$\pm 25\% @ 100 \sim 500 \mu\text{g}/\text{m}^3$ $\pm 25 \mu\text{g}/\text{m}^3 @ 0 \sim 100 \mu\text{g}/\text{m}^3$	
Particle Standard Volume	0.1	Litre (L)
Single Response Time	$< 1$	Second (s)
Total Response Time	$\leq 10$	Second (s)
DC Power Supply	Typ:5.0 Min:4.5 Max:5.5	Volt (V)
Active Current	$\leq 100$	Milliampere (mA)
Standby Current	2	Milliampere (mA)
Interface Level	L $< 0.8 @ 3.3$ H $> 2.7 @ 3.3$	Volt (V)
Working Temperature Range	-10~+60	$^{\circ}\text{C}$
Working Humidity Range	0~99%	
Storage Temperature Range	-40~+80	$^{\circ}\text{C}$
MTTF	$\geq 3$	Year
Physical Size	38x35x12	Millimeter (mm)

Note 1: Maximum range means that the highest output value of the PM2.5 standard data is not less than 1000.

<b>PLANTOWER</b> 攀藤科技	<b>PMSA003-A Datasheet</b>	DOCUMENT No	PTQ3033-2017
		Version	V1.0
		Date	2019-2-20

Note 2:“PM2.5 standard data” is the “data2” in the appendix A.20°C, 50%.

## 5. Output result

Mainly output as the quality and number of each particles with different size per unit volume, the unit volume of particle number is 0.1L and the unit of mass concentration is  $\mu\text{g}/\text{m}^3$ .

There are two options for digital output: stable mode and fast mode. If the concentration change is small the sensor would run at stable mode with the real interval of 2.3s.And if the change is big the sensor would be changed to fast mode automatically with the interval of 200~800ms, the higher of the concentration, the shorter of the interval.

## 6. Pin Definition

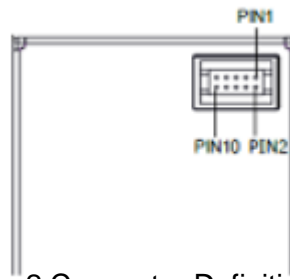

Figure 2 Connector Definition

Pin number	Pin name	Description
<b>PIN1</b>	VCC	Positive power 5V
<b>PIN2</b>	VCC	Positive power 5V
<b>PIN3</b>	GND	Negative power
<b>PIN4</b>	GND	Negative power
<b>PIN5</b>	RESET	Module reset signal/TTL level@3.3V, low reset
<b>PIN6</b>	NC	
<b>PIN7</b>	RXD	Serial port receiving pin /TTL level@3.3V
<b>PIN8</b>	NC	
<b>PIN9</b>	TXD	Serial port transmission pin /TTL level @3.3V

<b>PLANTOWER</b> 攀藤科技	<b>PMSA003-A Datasheet</b>	DOCUMENT No	PTQ3033-2017
		Version	V1.0
		Date	2019-2-20

<b>PIN10</b>	SET	Set pin/TTL level @3.3V, high level or suspending is normal working status, while low level is sleeping mode.
--------------	-----	---

## 7. Typical Circuit

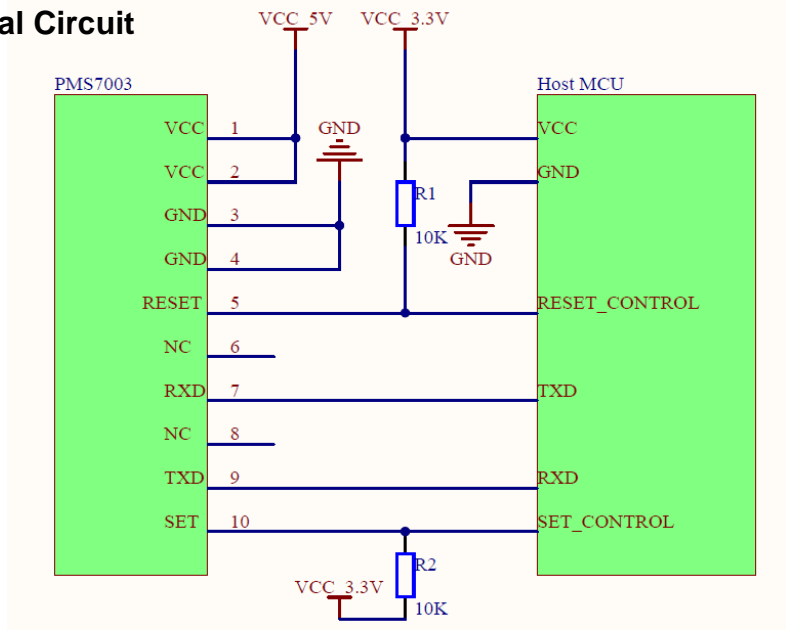

Figure 3 Typical Circuit

## 8. Circuit Attentions

- 1) DC 5V power supply is needed because the FAN should be driven by 5V. But the high level of data pin is 3.3V. Level conversion unit should be used if the power of host MCU is 5V.
- 2) The SET and RESET pins are pulled up inside so they should not be connected if without usage.
- 3) PIN6 and PIN8 should not be connected.
- 4) Stable data should be got at least 30 seconds after the sensor wakeup from the sleep mode because of the fan's performance.



<b>PLANTOWER</b> 攀藤科技	<b>PMSA003-A Datasheet</b>	DOCUMENT No	PTQ3033-2017
		Version	V1.0
		Date	2019-2-20

### 9. Typical Output Characteristic

Definition of axis Y: PM2.5 concentration, unit:  $\mu\text{g}/\text{m}^3$

Definition of axis X: number of samples, unit: time

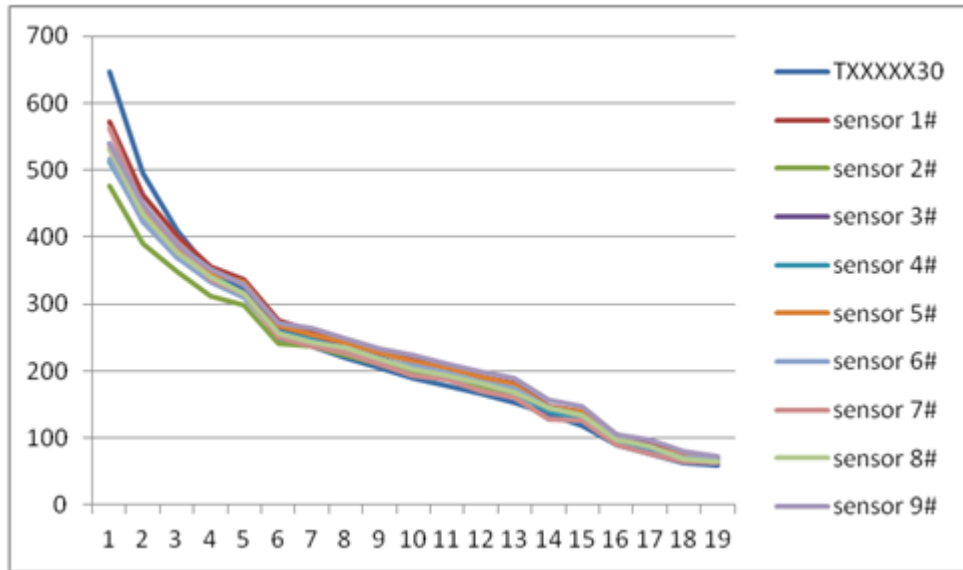

Figure 4-1 Consistency at 20°C

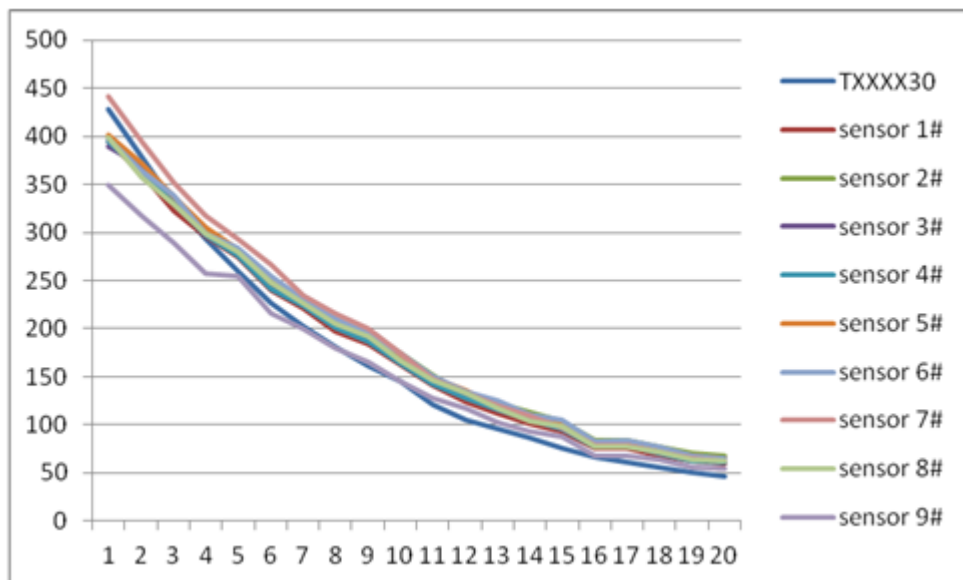

Figure 4-2 Consistency at 43°C

<b>PLANTOWER</b> 攀藤科技	<b>PMSA003-A Datasheet</b>	DOCUMENT No	PTQ3033-2017
		Version	V1.0
		Date	2019-2-20

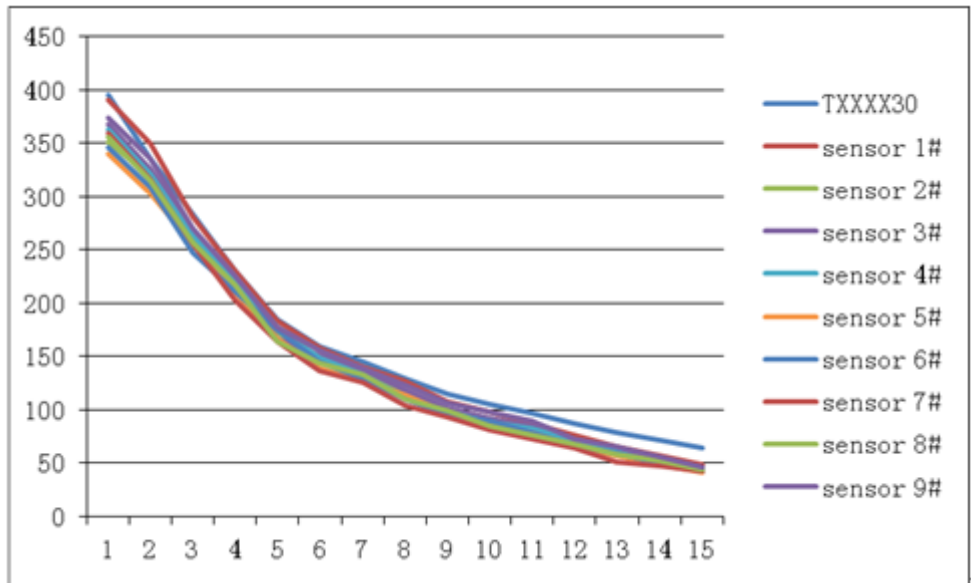

Figure 4-3 Consistency at -5°C

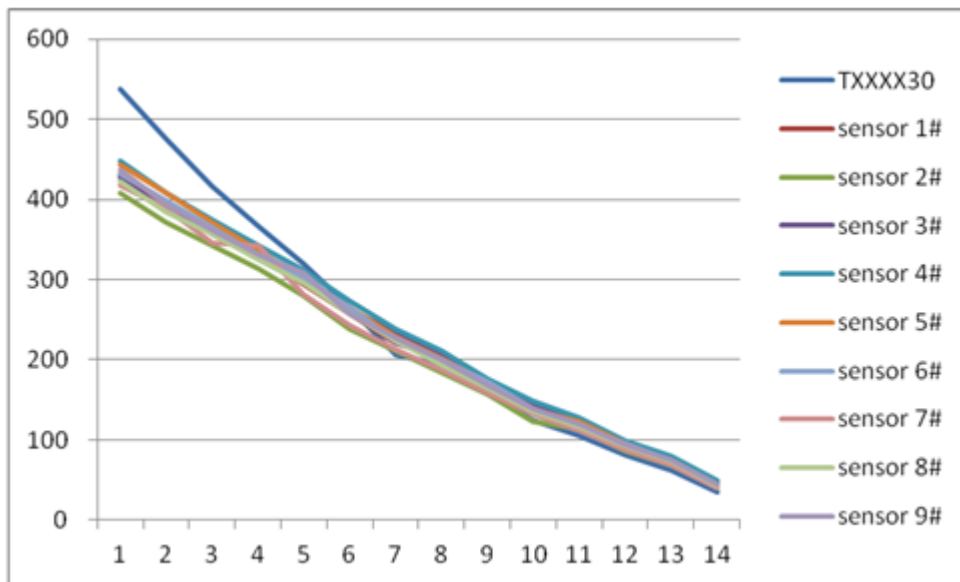

Figure 4-4 Consistency after 30 days running

<b>PLANTOWER</b> 攀藤科技	<b>PMSA003-A Datasheet</b>	DOCUMENT No	PTQ3033-2017
		Version	V1.0
		Date	2019-2-20

Relationship of Temperature and Consistency

Definition of axis Y: Maximum Error Modulus(%)

Definition of axis X: Temperature(°C)

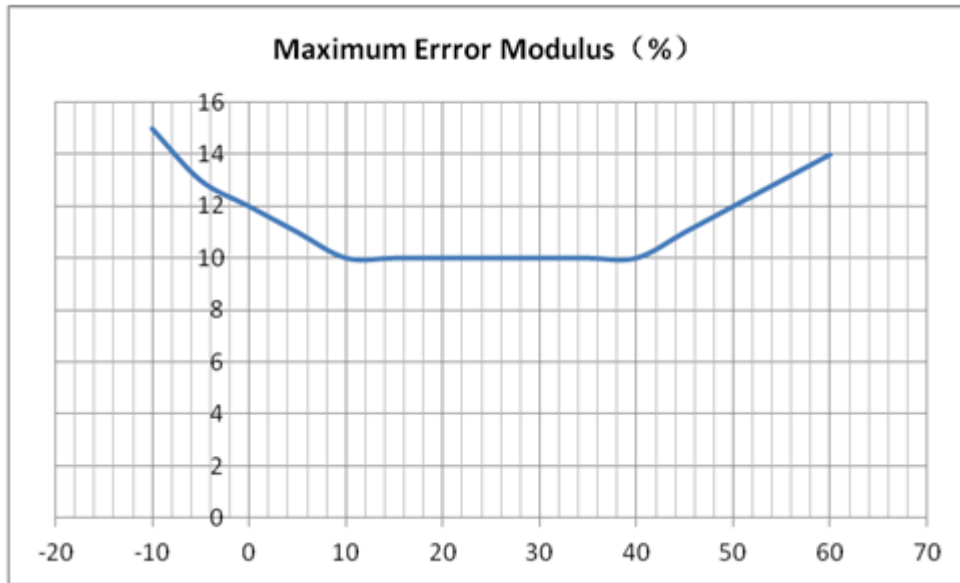

Figure 5 Consistency Vs Temperature

## 10. Endurance Characteristics

No	Item	Test Method	Characteristics	n C
1	Long Time Running	1. 30m <sup>3</sup> closed Lab, 20~30°C, humidity 30%~70%, particle generator and air cleaner 2. DC 4V power supply 3. Check consistency after 720 hours' running	10 samples during 0~500µg/m <sup>3</sup>  1. 0~100µg/m <sup>3</sup> Maximum Error ≤ ±15µg/m <sup>3</sup>	n=30 C=0

<b>PLANTOWER</b> 攀藤科技	<b>PMSA003-A Datasheet</b>	DOCUMENT No	PTQ3033-2017
		Version	VI.0
		Date	2019-2-20

2	High Temperature Operation	<ol style="list-style-type: none"> <li>Constant temperature Lab Particle generator and air cleaner</li> <li>70°C working 72 hours</li> <li>DC 4V power supply</li> <li>Check consistency at 20~30°C after 24hours' running</li> </ol>	<ol style="list-style-type: none"> <li>100~500µg/m<sup>3</sup> Maximum Error≤±15%</li> <li>FAN does not screeched</li> </ol>	n=10 C=0
3	Low Temperature Operation	<ol style="list-style-type: none"> <li>Constant temperature Lab Particle generator and air cleaner</li> <li>-20°C working 72 hours</li> <li>DC 4V power supply</li> <li>Check consistency at 20~30°C after 24hours' running</li> </ol>		n=10 C=0
4	Vibration	<ol style="list-style-type: none"> <li>Frequency: 50Hz.</li> <li>acceleration: 9.8m/ S<sup>2</sup>.</li> <li>Direction: X、Y、Z..</li> <li>Vibration Amplitude: ±2mm.</li> <li>Time: X、Y、Z-way, Per 60min</li> <li>DC 4V power supply and check consistency</li> </ol>		n=5 C=0
5	Polution test	Smoke in 3m3 test chamber, PM2.5 concentration remained stable above 1000ug/m3,storage 240hours		
6	High Temperature and Humidity Storage	<ol style="list-style-type: none"> <li>Constant temperature Lab Particle generator and air cleaner</li> <li>80±2°C humidity 90~95% storage 100 hours</li> <li>DC 4V power supply</li> <li>check consistency at 20~30°C after 24hours' running</li> </ol>	<ol style="list-style-type: none"> <li>10 samples during 0~500µg/m<sup>3</sup></li> <li>0~100µg/m<sup>3</sup> Maximum Error≤±10µg/m<sup>3</sup></li> <li>100~500µg/m<sup>3</sup> Maximum Error≤±10%</li> </ol>	n=10 C=0
7	Low Temperature Storage	<ol style="list-style-type: none"> <li>Constant temperature Lab Particle generator and air cleaner</li> <li>-40±2°C storage 100 hours</li> <li>DC 4V power supply</li> <li>check consistency at 20~30°C after 24hours' running</li> </ol>		n=10 C=0

<b>PLANTOWER</b> 攀藤科技	<b>PMSA003-A Datasheet</b>	DOCUMENT No	PTQ3033-2017
		Version	VI.0
		Date	2019-2-20

8	Variation of Power Supply	<ol style="list-style-type: none"> <li>30m<sup>3</sup> closed Lab,, 20~30℃, humidity 30%~70%, particle generator and air cleaner</li> <li>Power varies as the cycles of 3.9V to 4.2V ,then 4.2V to 3.9V with the pace of 0.1V/min for 2 hours.</li> <li>Check consistency during Variation</li> </ol>		n=5 C=0
9	Power On-Off Cycle	<ol style="list-style-type: none"> <li>30m<sup>3</sup> closed Lab,, 20~30℃, humidity 30%~70%, particle generator and air cleaner</li> <li>DC 4V power supply, keep On-Off frequency 0.5Hz for 72 hours and check consistency</li> <li>Check consistency after cycle.</li> </ol>		n=10 C=0
10	Laser On-Off Cycle	<ol style="list-style-type: none"> <li>30m<sup>3</sup> closed Lab,, 20~30℃,humidity 30%~70%,particle generator and air cleaner</li> <li>Keep laser On-Off frequency 100Hz for 240 hours</li> <li>Check consistency after cycle.</li> </ol>		n=10 C=0
11	Salt Spray	The concentration of 5% NACL solution for spray under 35 ℃ 8 h, 16 h dry, salt fog settlement for 1 ~ 2 ml (with 80 square centimeters funnel collection)	No rust discoloration of metal parts, Consistency of mass concentration within specification range	n=1 C=0
12	Shell shielding	Switch the multimeter to the resistance, and the two meter tips are placed on the shielding housing on both sides of the sensor	The shielding shells on both sides shall be connected	
13	The zeroTest	<ol style="list-style-type: none"> <li>30m<sup>3</sup> closed Lab,20~30℃, humidity 30%~70%, air cleaner to 0ug/m3</li> <li>DC 4V power supply and check consistency</li> </ol>	PM2.5 value less than 3ug/m3	

<b>PLANTOWER</b> 攀藤科技	<b>PMSA003-A Datasheet</b>	DOCUMENT No	PTQ3033-2017
		Version	V1.0
		Date	2019-2-20

### 11. Part Number Definition

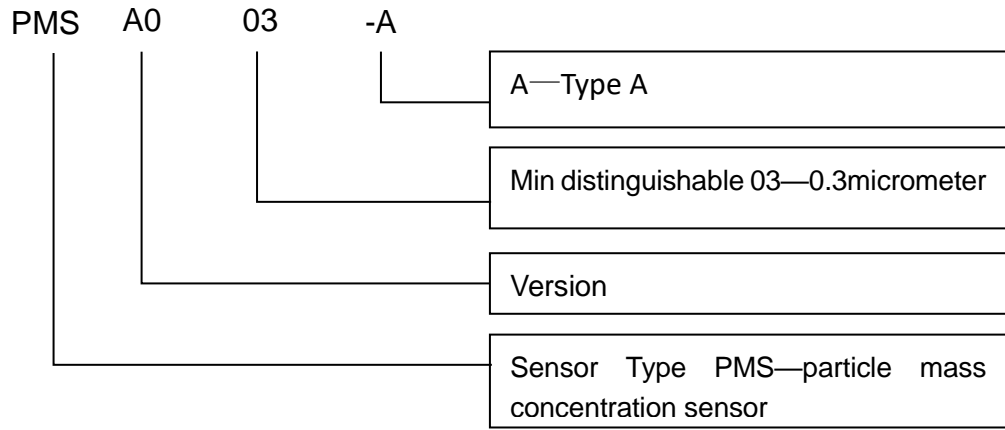

## 12. Physical Size

(Unit:mm)

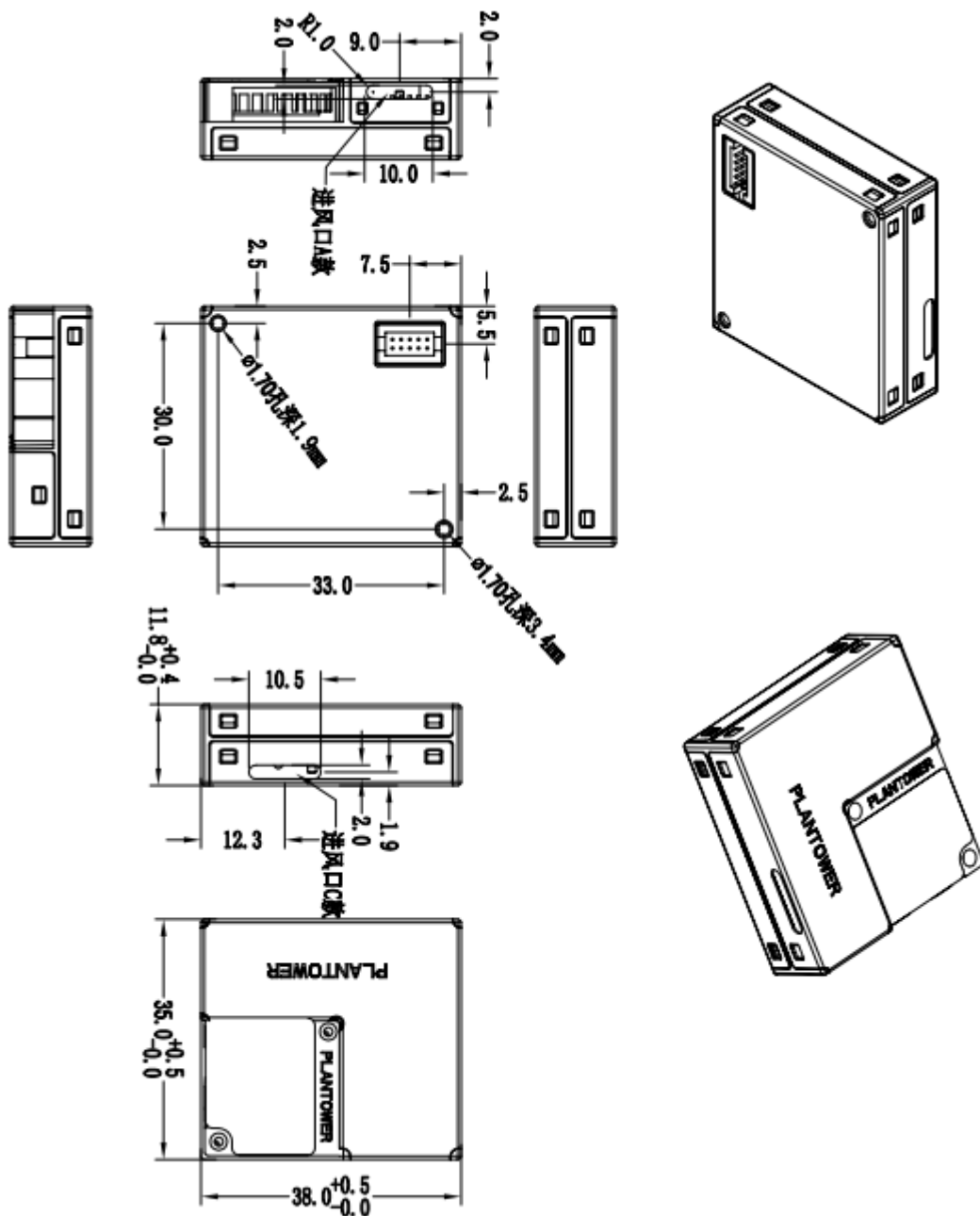

<b>PLANTOWER</b> 攀藤科技	<b>PMSA003-A Datasheet</b>	DOCUMENT No	PTQ3033-2017
		Version	V1.0
		Date	2019-2-20

### 13. Installation Attentions

- 1) Metal shell is connected to the GND so be careful not to let it shorted with the other parts of circuit except GND.
- 2) The best way of install is making the plane of inlet and outlet closely to the plane of the host. Or some shield should be placed between inlet and outlet in order to prevent the air flow from inner loop.
- 3) The blowhole in the shell of the host should not be smaller than the inlet.
- 4) The sensor should not be installed in the air flow way of the air cleaner or should be shielded by some structure.
- 5) The sensor should be installed at least 20cm higher than the grand in order to prevent it from blocking by the flock dust.
- 6) When the sensor is used to outdoor fixed equipment, the equipment should be completed for the protection of sandstorm,rain,snow,etc.
- 7) Do not break up the sensor.

### 14. Other Attentions

- 1) Only the consistency of all the PM sensors of PLANTOWER is promised and ensured. And the sensor should not be checked with any third party equipment.
- 2) The sensor is usually used in the common indoor environment. So some protection must be added if using in the conditions as followed:
  - a) The time of concentration  $\geq 300\mu\text{g}/\text{m}^3$  is longer than 50% of the whole year or concentration  $\geq 500\mu\text{g}/\text{m}^3$  is longer than 20% of the whole year.
  - b) Kitchen



<b>PLANTOWER</b> 攀藤科技	<b>PMSA003-A Datasheet</b>	DOCUMENT No	PTQ3033-2017
		Version	V1.0
		Date	2019-2-20

- c) Water mist condition such as bathroom or hot spring.
- d) Outdoor

## 15. Appendix A: Transport Protocol Active Mode

Default baud rate: 9600bps    Check bit: None    Stop bit: 1 bit

32 Bytes

Start character 1	0x42	(Fixed)
Start character2	0x4d	(Fixed)
Frame length high 8 bits	.....	Frame length=2x13+2(data+check bytes)
Frame length low 8 bits	.....	
Data 1 high 8 bits	.....	Data1 refers to PM1.0 concentration unit $\mu$ g/m <sup>3</sup> (CF=1, standard particle) *
Data 1 low 8 bits	.....	
Data2 high 8 bits	.....	Data2 refers to PM2.5 concentration unit $\mu$ g/m <sup>3</sup> (CF=1, standard particle)
Data2 low 8 bits	.....	
Data3 high 8 bits	.....	Data3 refers to PM10 concentration unit $\mu$ g/m <sup>3</sup> (CF=1, standard particle)
Data3 low 8 bits	.....	
Data4 high 8 bits	.....	Data4 refers to PM1.0 concentration unit * $\mu$ g/m <sup>3</sup> (under atmospheric environment)
Data4 low 8 bits	.....	
Data5 high 8 bits	.....	Data 5 refers to PM2.5 concentration unit $\mu$ g/m <sup>3</sup> (under atmospheric environment)
Data5 low 8 bits	.....	
Data6 high 8 bits	.....	Data 6 refers to PM10 concentration unit $\mu$ g/m <sup>3</sup> (under atmospheric environment)
Data6 low 8 bits	.....	
Data7 high 8 bits	.....	Data7 indicates the number of particles with diameter beyond 0.3 um in 0.1 L of air.

<b>PLANTOWER</b> 攀藤科技	<b>PMSA003-A Datasheet</b>	DOCUMENT No	PTQ3033-2017
		Version	V1.0
		Date	2019-2-20

Data7 low 8 bits	.....	
Data8 high 8 bits	.....	Data8 indicates the number of particles with diameter beyond 0.5 um in 0.1 L of air.
Data8 low 8 bits	.....	
Data9 high 8 bits	.....	Data9 indicates the number of particles with diameter beyond 1.0 um in 0.1 L of air.
Data9 low 8 bits	.....	
Data10 high 8 bits	.....	Data10 indicates the number of particles with diameter beyond 2.5 um in 0.1 L of air.
Data10 low 8 bits	.....	
Data11 high 8 bits	.....	Data11 indicates the number of particles with diameter beyond 5.0 um in 0.1 L of air.
Data11 low 8 bits	.....	
Data12 high 8 bits	.....	Data12 indicates the number of particles with diameter beyond 10 um in 0.1 L of air.
Data12 low 8 bits	.....	
Data13 high 8 bits	.....	Version
Data13 low 8 bits	.....	error code
Data and check high 8 bits	.....	Check code=Start character 1+ Start character 2+.....+data 13 low 8 bits
Data and check low 8 bits	.....	

Note: CF=1 should be used in the factory environment

## 16. Appendix B: Transport Protocol Passive Mode

Default baud rate: 9600bps Check bit: None Stop bit: 1 bit

### 1) Host Protocol

Start Byte 1	Start Byte 2	Command	Data 1	Data 2	Verify Byte 1	Verify Byte 2
0x42	0x4d	CMD	DATAH	DATAL	LRCH	LRCL

<b>PLANTOWER</b> 攀藤科技	<b>PMSA003-A Datasheet</b>	DOCUMENT No	PTQ3033-2017
		Version	V1.0
		Date	2019-2-20

## 2) Command Definition

CMD	DATAH	DATAL	Note
0xe2	X	X	Read in passive mode
0xe1	X	00H-passive 01H-active	Change mode
0xe4	X	00H-sleep 01H-wakeup	Sleep set

## 3) Answer

a) 0xe2: 32bytes , same as appendix I

b) 0xe1:

Start Byte 1	Start Byte 2	Frame length1	Frame length2	Command	Data	Verify Byte 1	Verify Byte 2
0x42	0x4d	0x00	0x04	0xe1	work	LRCH	LRCL

c) 0xe4:

Start Byte 1	Start Byte 2	Frame length1	Frame length2	Command	Data	Verify Byte 1	Verify Byte 2
0x42	0x4d	0x00	0x04	0xe4	sleep	LRCH	LRCL

## 4) Verify Bytes :

Add of all the bytes except verify bytes.